

## Kitchen faucet ULTRA-33

Product information

RUBINETA  
**Extra**



### Description

Faucets Ultra successfully stand out from the others due to their simplicity and minimalism of shapes.

- 5-years warranty
- After assembly all our faucets are being 100% tested
- Durable and glossy surface on all our faucets. We use more durable coating for shine and long-term use of faucets, which is more resistant to scratches, dents, limescale, rust.
- High-quality brass with lowered content of harmful impurities is one of the most important component materials.
- Faucets with the ANTI-NOISE system work silently and do not cause discomfort.
- Air and water mixing technology ensures exceptional economy.
- Save water and energy resources with our RubiSave cartridge. Having bought a faucet with the RubiSave cartridge, you can not only regulate the water consumption, but also the temperature and so reduce the consumption of water up to two times
- Faucet is supplied with 40 mm ceramic cartridge, ensuring longlasting and flawless performance of the faucet.
- Aerator Neoperl® Honeycomb – ensures longlasting, quiet and flawless performance of the faucet.
- Faucet is complemented with 40 cm connection hoses.



### Specification

<b>Code</b>	U30008
<b>Intended use</b>	Kitchen faucet
<b>EAN</b>	4779028802427
<b>Warranty</b>	5
<b>Series</b>	Ultra
<b>Segment</b>	Extra
<b>Connection</b>	1/2
<b>Finish</b>	Chrome plated
<b>Debit l/m</b>	12.1

### Components



618040



634009



636739

EAN: 4779028804469 EAN: 4779028800027 EAN: 4779035274385

## Scheme

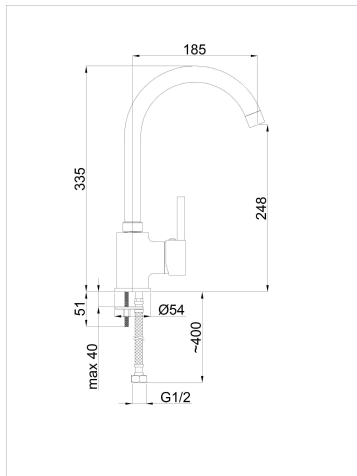

## Package



<b>Package quantity</b>	12
<b>Weight Brutto (kg)</b>	1.5283
<b>Weight Netto (kg)</b>	1.15663
<b>1 package length (m)</b>	0.08
<b>1 packaging depth (m)</b>	0.376
<b>The primary package width (m)</b>	0.202
<b>2 package weight (kg)</b>	0.92
<b>2 packaging capacity</b>	0.08461
<b>2 Packaging depth (m)</b>	0.51
<b>2 packaging length (m)</b>	0.42
<b>2 packaging width (m)</b>	0.395